

CAST IRON CAP BY KING SUPPLY CO.
(800-542-2379)
PART: 45-809
OR
CRESCENT CITY IRON SUPPLY INC.
(800-535-9842)
PART: MI-144

CONTINUOUS WELD CAP TO POST
 $\frac{3}{8}$ " CHAIN-PROOF COIL, ZINC PLATED
BLACK POLY COATED
#012-0622
 $\frac{3}{8}$ " LAP LINK CONNECTOR (TYP.)
WELD CLOSE PAINT GLOSS BLACK
 CHAIN & CONNECTOR LINK SUPPLIER:
COMMERCIAL GROUP
G-2427 EAST JUDD RD.
BURTON, MI 48527
(810-744-4540)
ATTN: DARREN NEWTON
 7' LONG, 4" SQ.; $\frac{1}{4}$ " WALL STEEL
PAINTED GLOSS BLACK

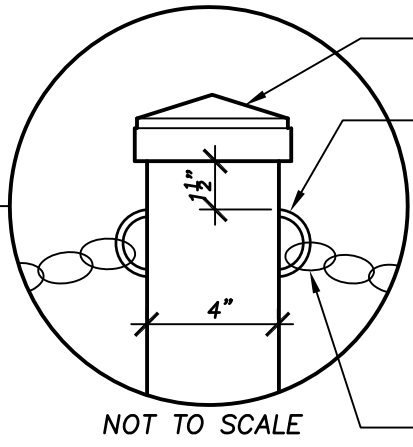

CONTINUOUS WELD
CAP TO POST
 $\frac{3}{8}$ " ROUND
STEEL, 1"
RADIUS;
CONTINUOUS
WELD
CENTERED ON
OPPOSITE
SIDES 1- $\frac{1}{2}$ "
BELOW
BOTTOM OF
CAP
 $\frac{3}{8}$ " LAP LINK
CONNECTOR
WELD CLOSE,
PAINT GLOSS
BLACK

NOT TO SCALE

33" MIN MEASURED AT LOW POINT (SEE NOTE 1)

42"

GRADE
 $\frac{1}{2}$ " WASH ON THE TOP SURFACE OF THE
CONCRETE FOOTING
 10" DIAMETER CONCRETE FOOTING
(SURROUND WITH $\frac{1}{2}$ " NON-EXTRUDING
EXPANSION JOINT WHEN PLACED IN
CONCRETE FLATWORK)
 DEFORM THE BOTTOM OF THE POST $\frac{1}{2}$ " TO
SECURE IT IN THE CONCRETE FOOTING

- NOTES:
- CHAIN SHALL
 - BE AS TIGHT AS POSSIBLE BETWEEN POSTS
 - HAVE A UNIFORM SAG BETWEEN THE UPPER AND LOWER CHAIN
 - BE VISUALLY UNIFORM BETWEEN POSTS
 - CHAIN SHALL NOT BE TWISTED
 - PRE-PAINT CONNECTOR LINK BEFORE INSTALLATION & WELDING. TOUCH UP PRIMER & PAINT AFTER WELDING.
 - POST SPACING SHALL BE UNIFORM BETWEEN END POSTS AT A 8' SPACING \pm 6".
 - PAINT: ELECTROSTATICALLY APPLIED.
PRIMER: RECOATABLE EPOXY, SHERWIN WILLIAMS (B67A5) (ONE COAT) 4-6 MILS
FINISH CONTAINS: 2-COMPONENT URETHANE ENAMEL "SHERTHANE 2K URETHANE" (B65W151) BY SHERWIN WILLIAMS (TWO COATS) 2-4 MILS EACH

2'-9"

6"

10"

X POST AND CHAIN - VEHICLE BARRIER
 X-X SCALE: 1"=1'-0"

SEE SPECIFICATION SECTION
324000 SITE APPURTENANCES
033000 CAST-IN-PLACE CONCRETE

CS_STD_CIV_324000_POST_AND_CHAIN_VEHICLE.dwg

MICHIGAN STATE UNIVERSITY Infrastructure Planning and Facilities	POST AND CHAIN - VEHICLE BARRIER Typical Detail		DATE 01/07/09	DETAIL NO. 324000-09	SHEET  OF ONE
			DRAWN	REVISION 11/15/13 JGUNTHER	