

DESIGNER NOTE: APPLICABLE WHEN HUMIDIFIER MANUFACTURER DOES NOT RECOMMEND CONDENSATE RETURN AND ADVISES TO QUENCH CONDENSATE AND RUN TO DRAIN.

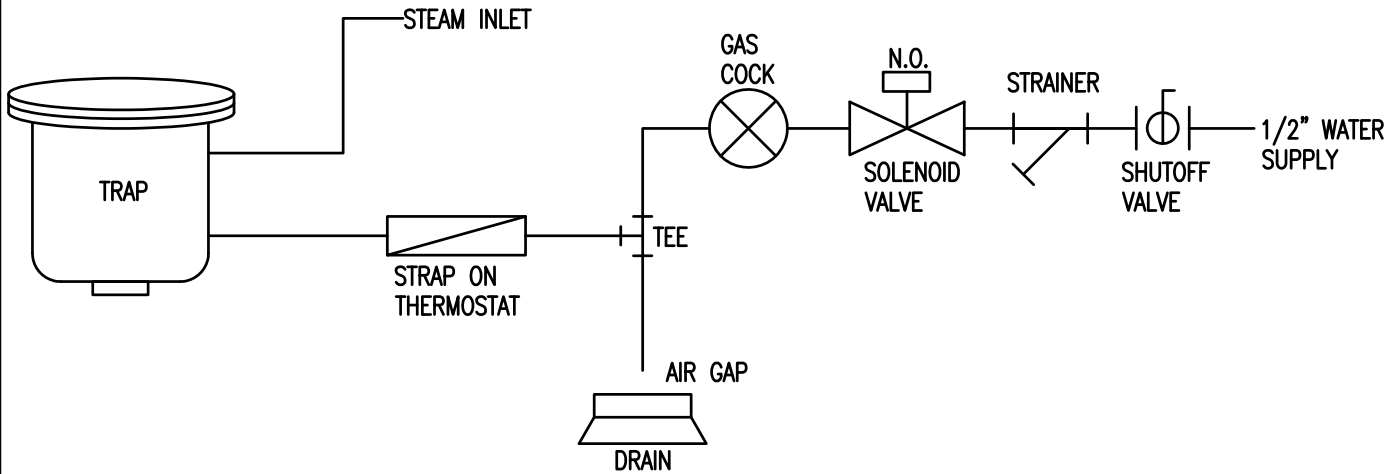

STEAM CONDENSATE WATER COOLER

NOTES:

1. SOLENOID VALVE – 1/2” NPT, NORMALLY OPEN, 24 VAC COIL ASCO P/N: 8210G34-24/60
–PROVIDED BY TCC AND INSTALLED BY MECHANICAL CONTRACTOR.
2. STRAP ON THERMOSTAT / AQUASTAT – JOHNSON CONTROL P/N: A19DAC-1
–PROVIDED BY TCC AND INSTALLED BY MECHANICAL CONTRACTOR.

CS_STD_MEC_STEAM_CONDENSATE_WATER_COOLER.dwg